

Cool The Earth by 1°C

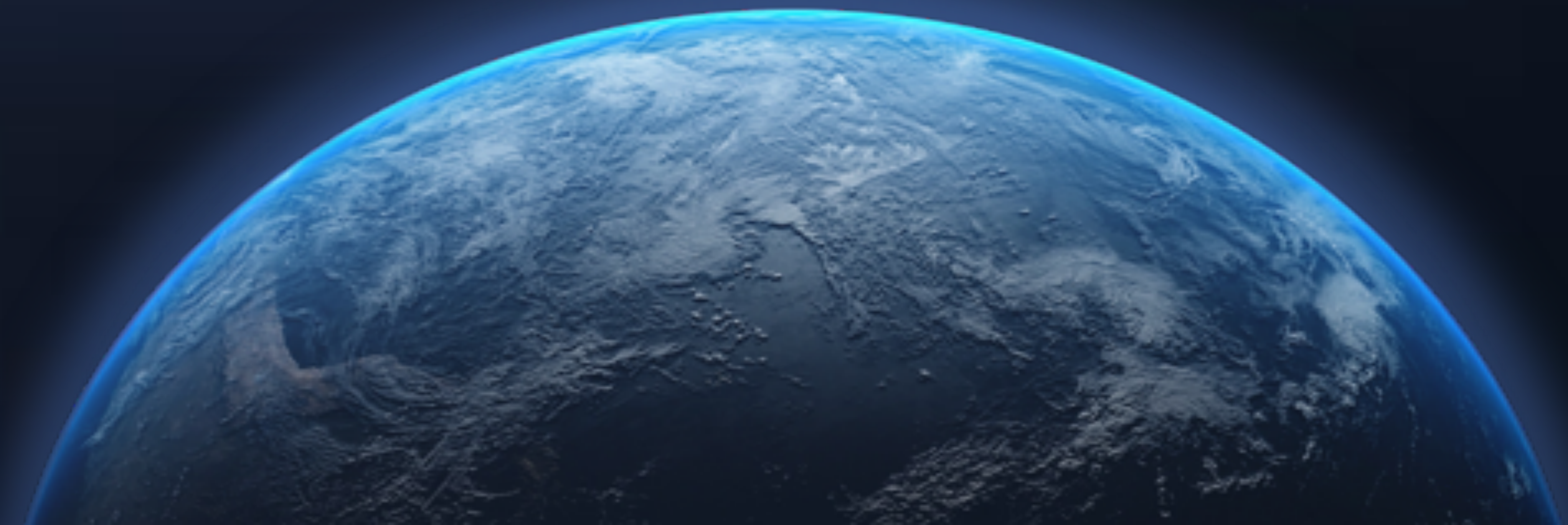

Build Your Dreams

The first and only company in the world to provide full market new energy vehicle solutions

Global NEV leader



No. 1 China NEV sales for **9** consecutive years (2013~2021)

593,745 units, 231.6% YoY growth

No. 1 global NEV sales in H1 2022

638,157 units, 324.8% YoY growth

BYD Passenger Vehicle Sales in 2021 & 2022

Sales(x1,000)

ICEV PHEV BEV

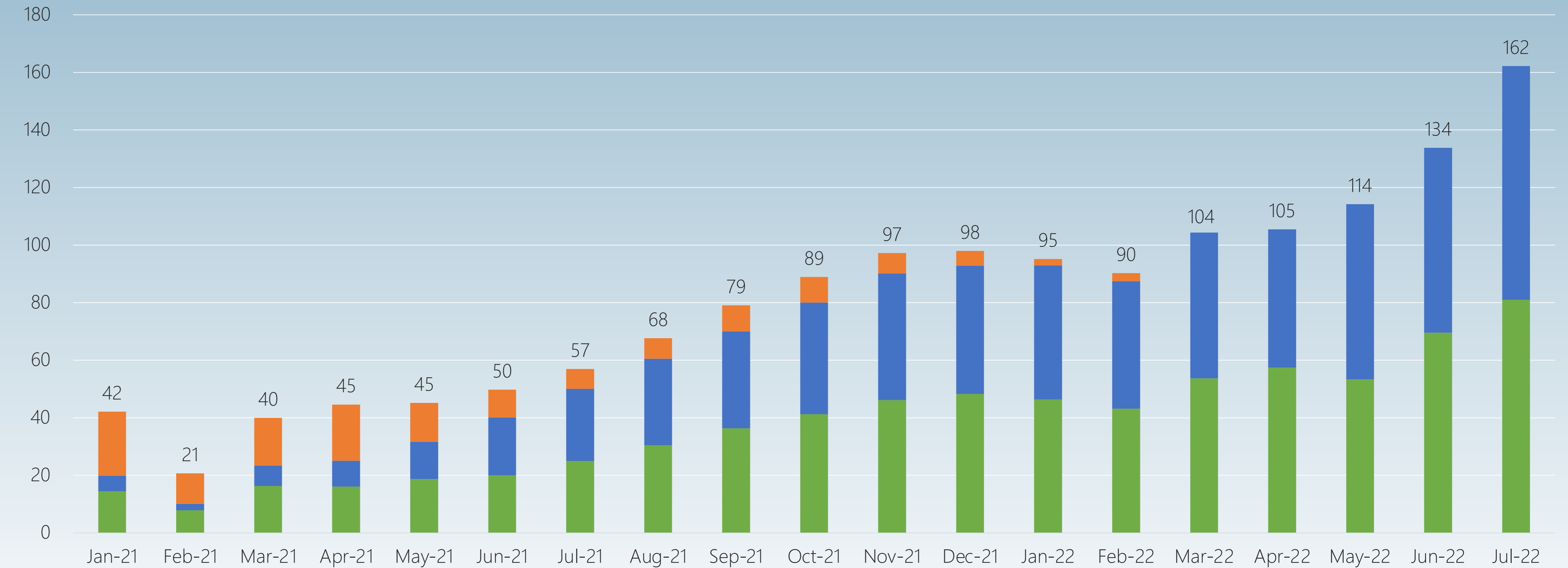

BYD at a glance



290K
Employees

40,000
Engineers

11
Research Institutes



30+
Industrial Parks

40+
Branch Offices



37,000
Patent Applications

25,000
Authorized Patents

Electronics



New Energy



Automobile



Rail Transit



Group revenue

€32 billion

2021 annual revenue

2022 Fortune Global 500



Group revenue (million EUR)
Currency: 1 EUR = 6.85 RMB

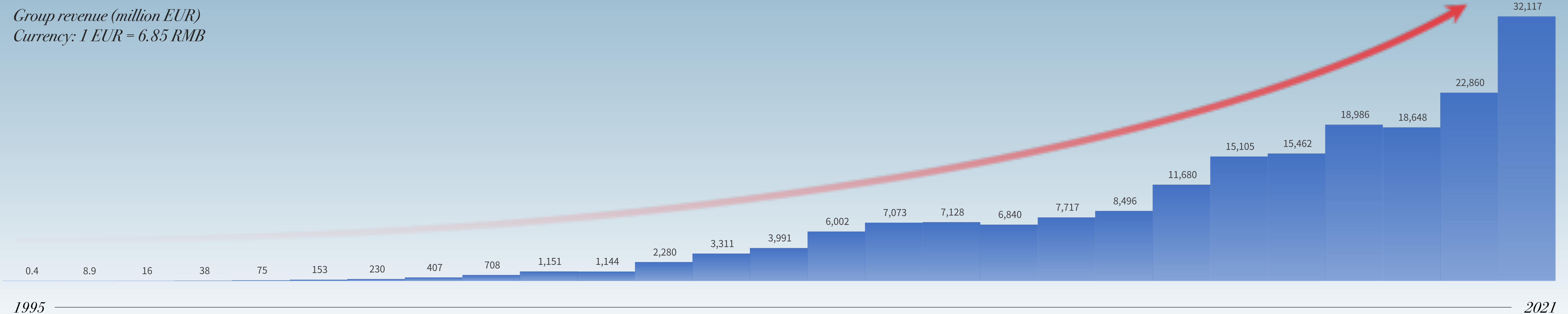

Milestones

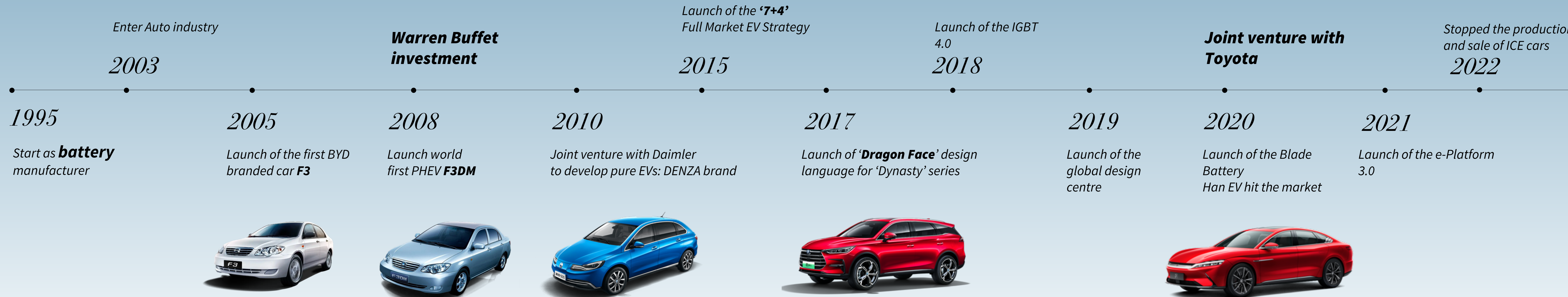

Global NEV leader

BYD

2.3 million

new energy passenger vehicles
provided to customers

85,000

pure electric commercial
vehicles delivered



Global NEV footprint



70+
Countries

400+
Cities

12 million tonnes
CO₂ emission reduction

As of July 2022

Total transport solutions in Europe



As of July 2022

BYD Europe



- Headquarters
- Subsidiaries
- ⚙️ Production Sites
- ⚙️ BYD ADL Joint Production



Market eBus leader

23
countries

133
cities

3000+
In operation and ordered

 **> 192,000** tonnes

 **> 179** million km in service



Brand Position



Premium

Deliver the important values of premium with leading technologies, advanced powertrains, quality of engineering and manufacturing

Accessible

Vehicles specifications allow consumers to enjoy generous standard equipment without paying excessively for optional features

What sets BYD apart?



High-tech DNA

Total mobility solutions

Vertical integration

Technology Based · *Innovation Oriented*

Core competencies



Power
Battery

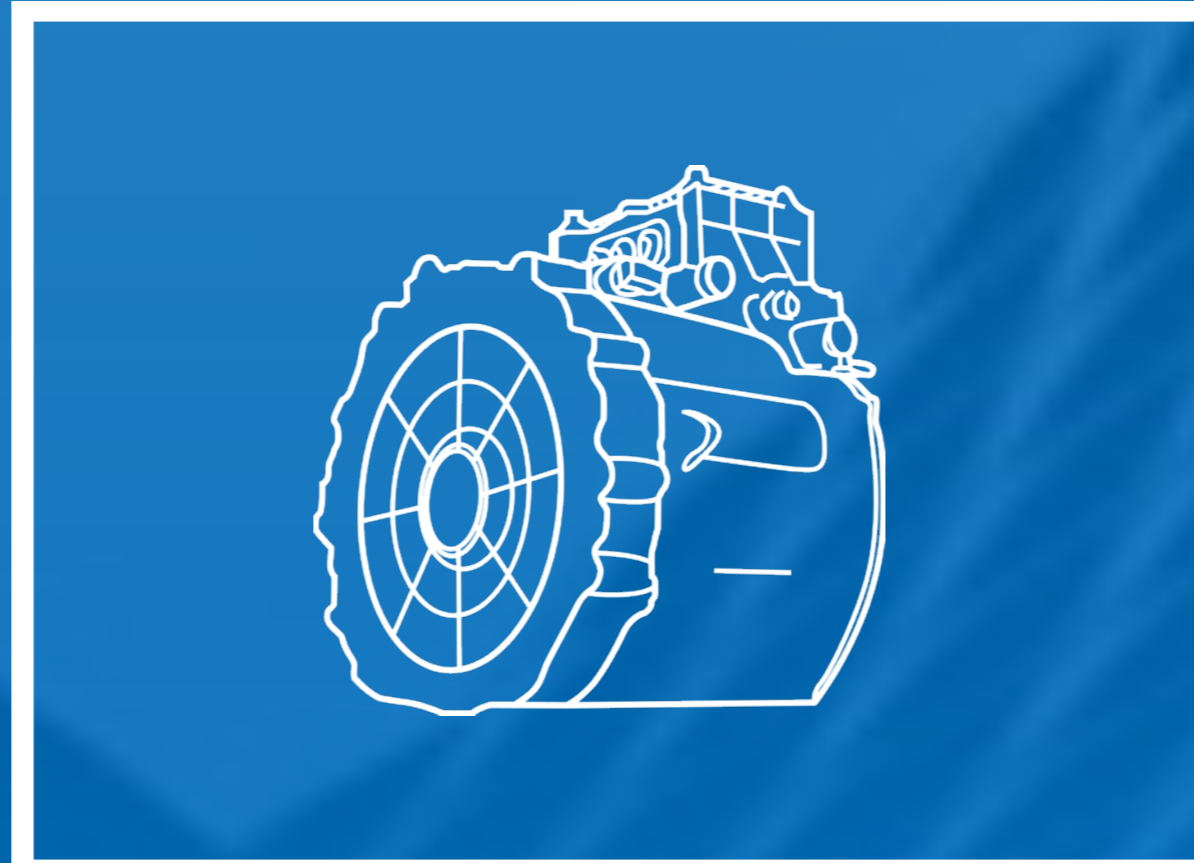

Electric
Motor

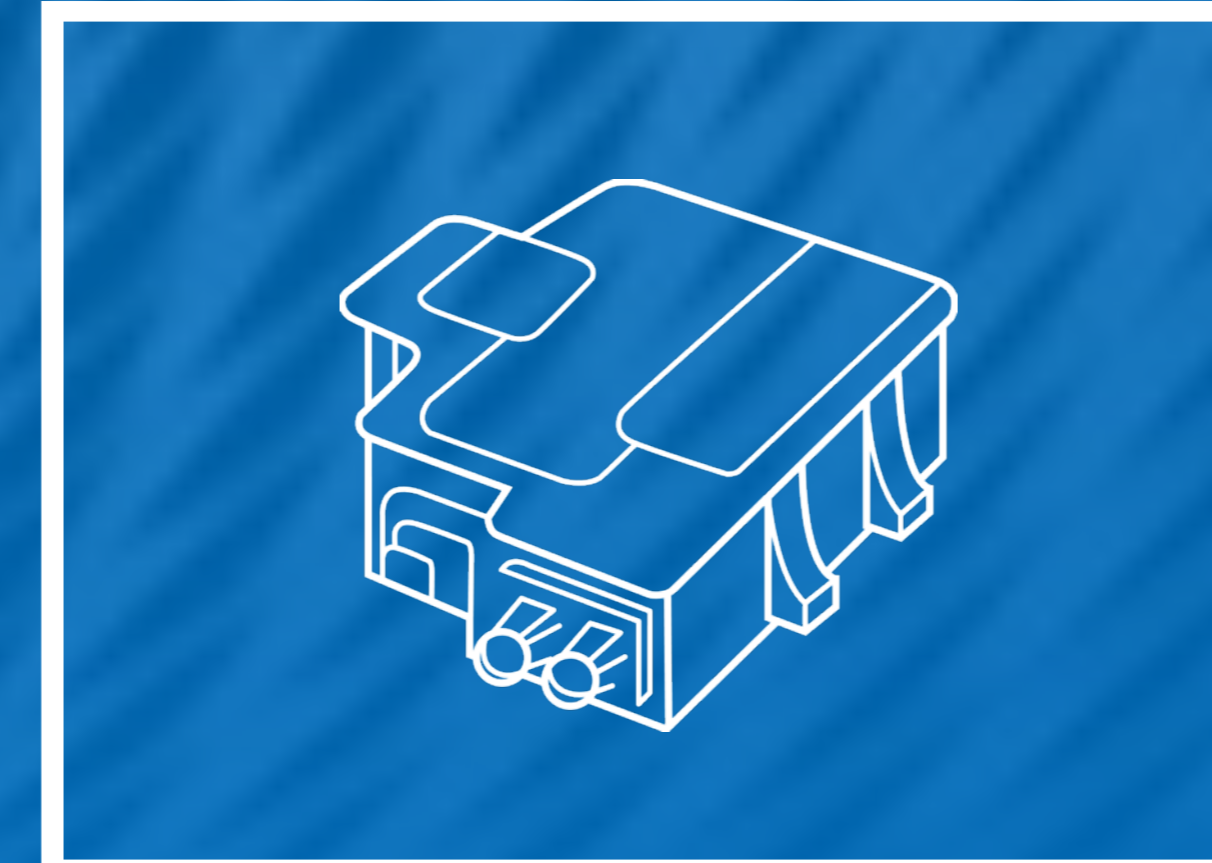

Electronic
Controller

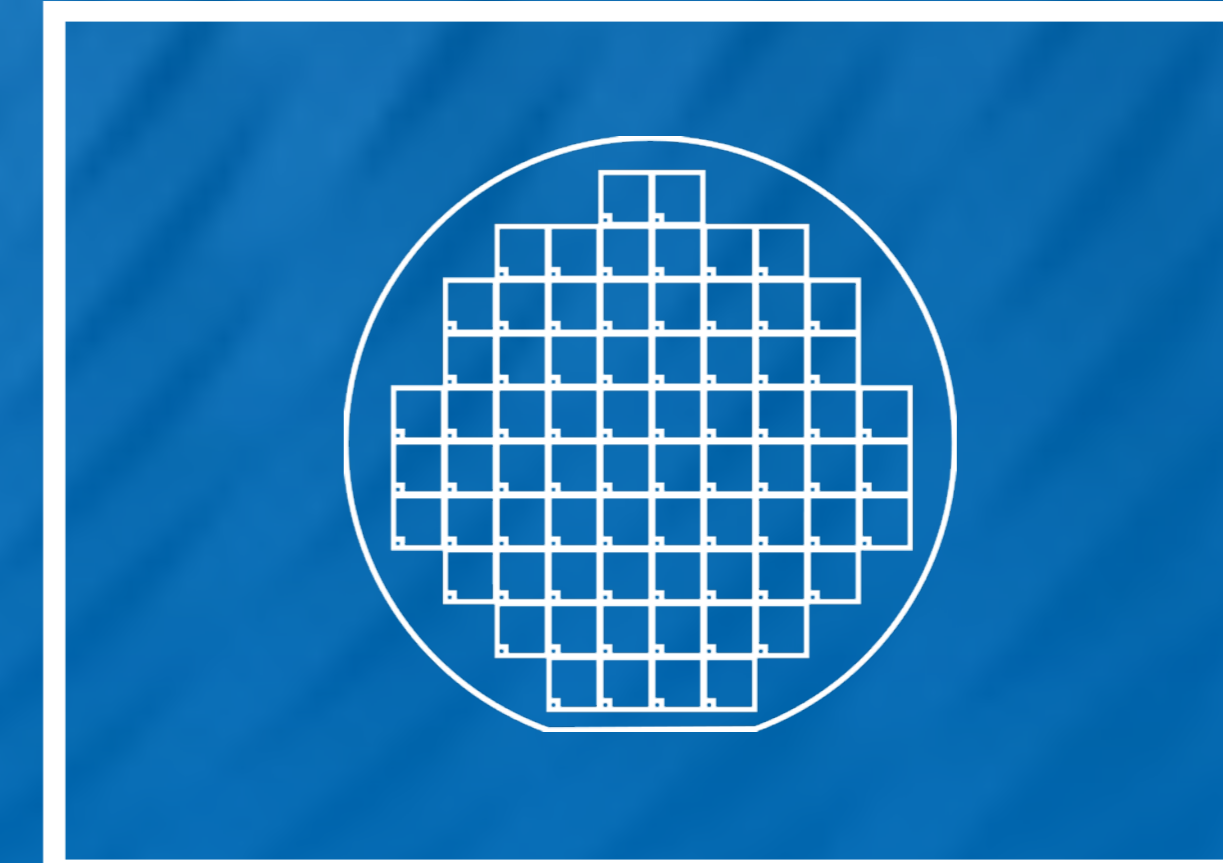

Power
Semiconductor

Blade Battery

Safe | Strong | Long Range | Long Lifespan

BYD



Cell to Pack (CTP) Technology



Traditional LFP
cells — modules — pack

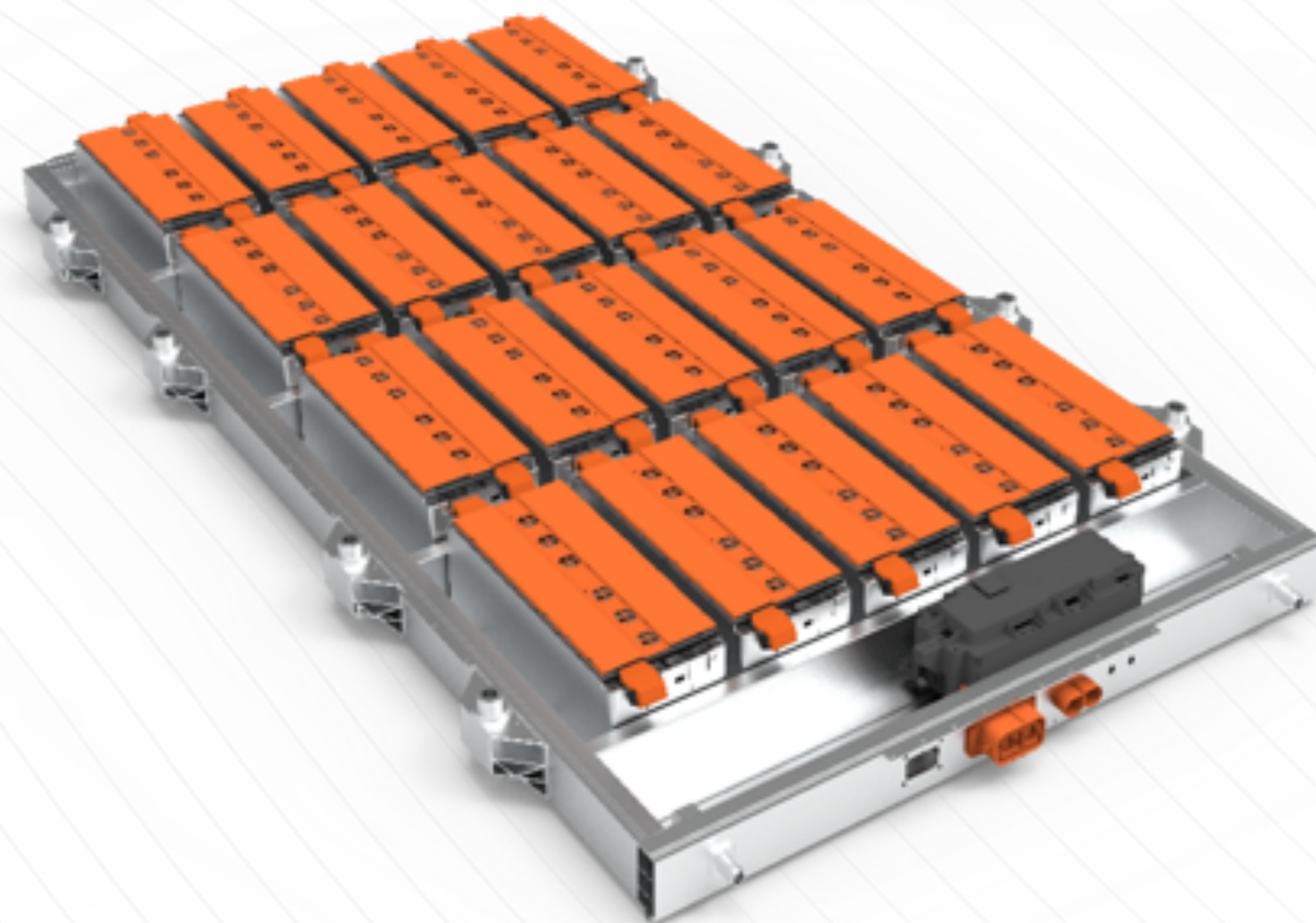

Blade Battery
cells — pack

+50%
space utilization



e-Platform 3.0

Safety | Efficiency | Intelligence | Spacious cabin

BYD



e-Platform 3.0

Safety

High efficiency

Intelligence

Spacious cabin

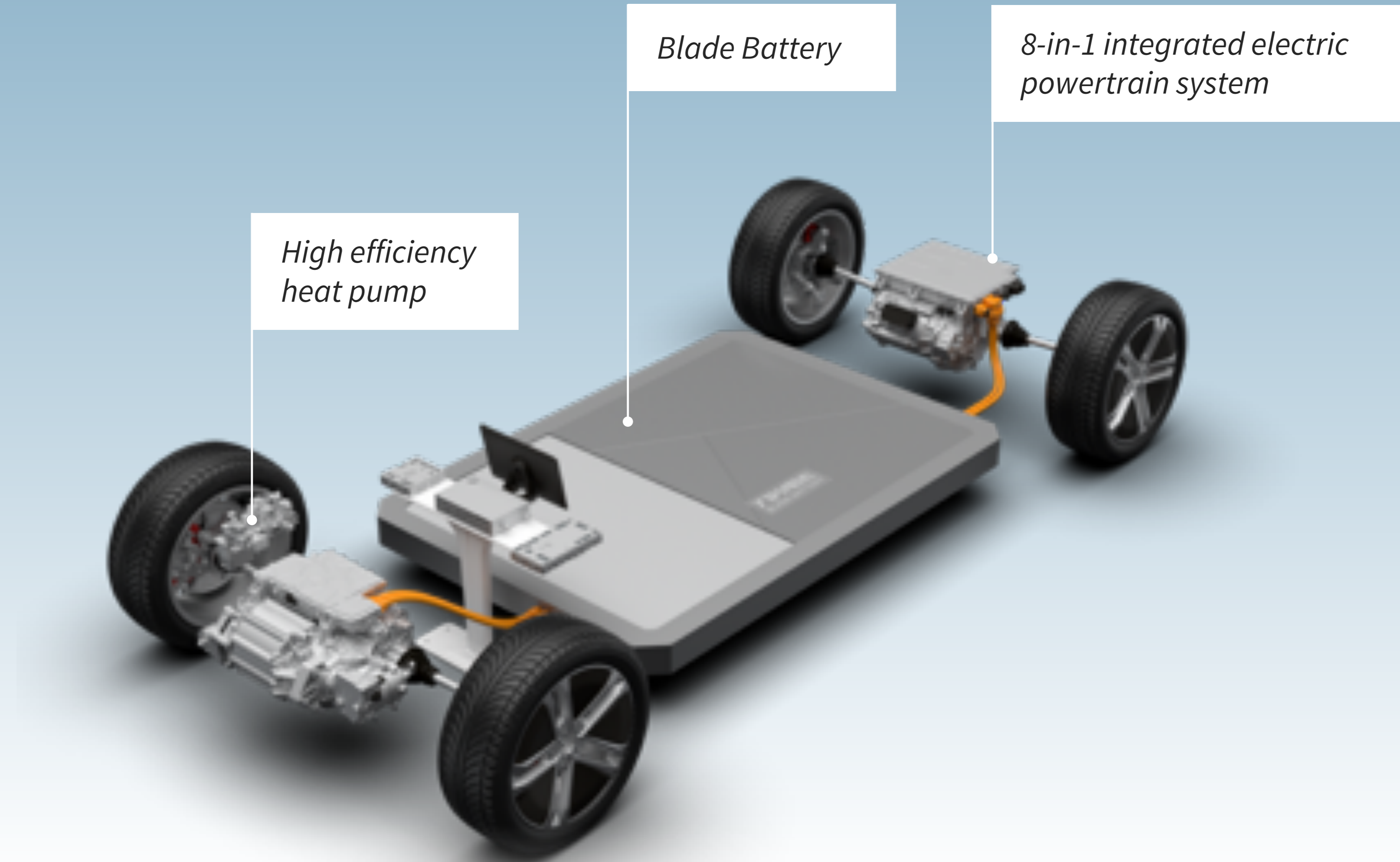

Safety

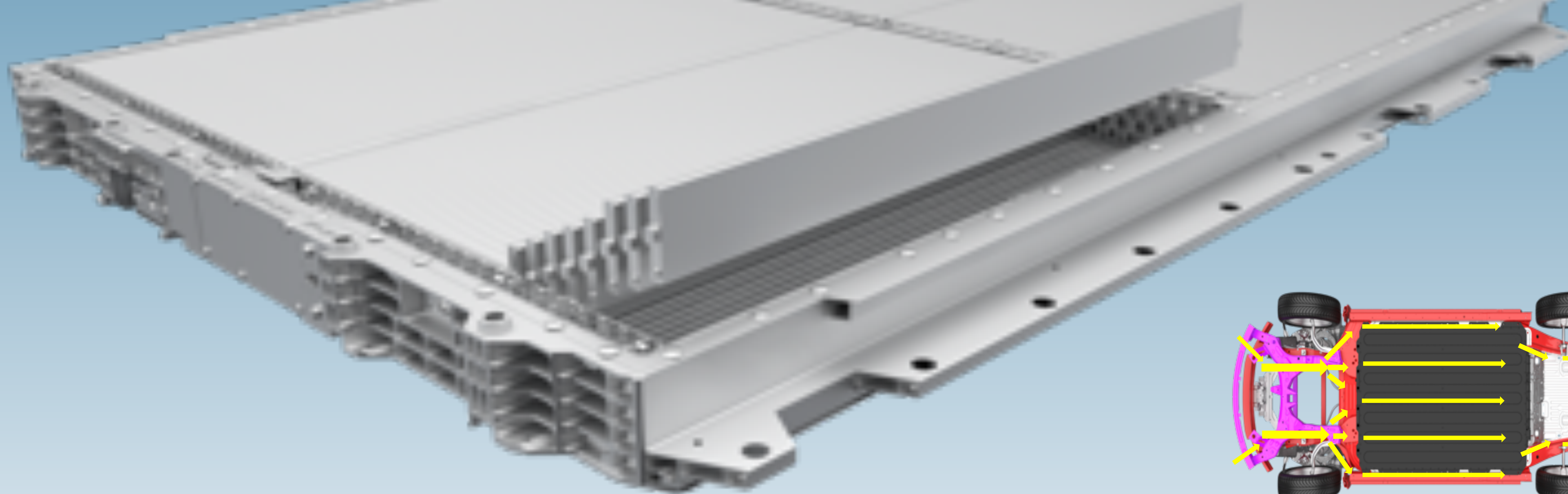

Blade Battery as standard

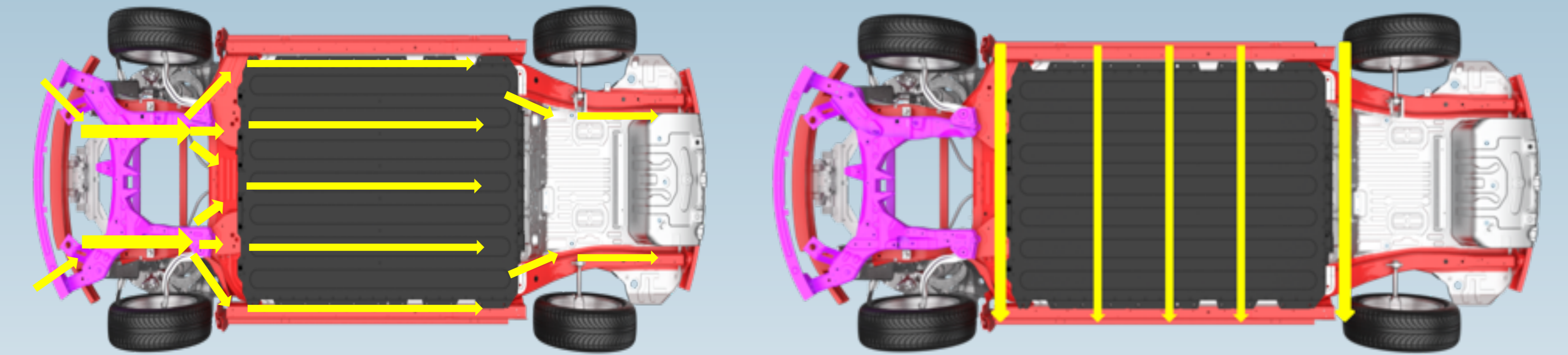

Force transmission path exclusively for pure EV ensures better protection

High efficiency

World's first mass-produced
8-in-1 electric powertrain

89%
system efficiency

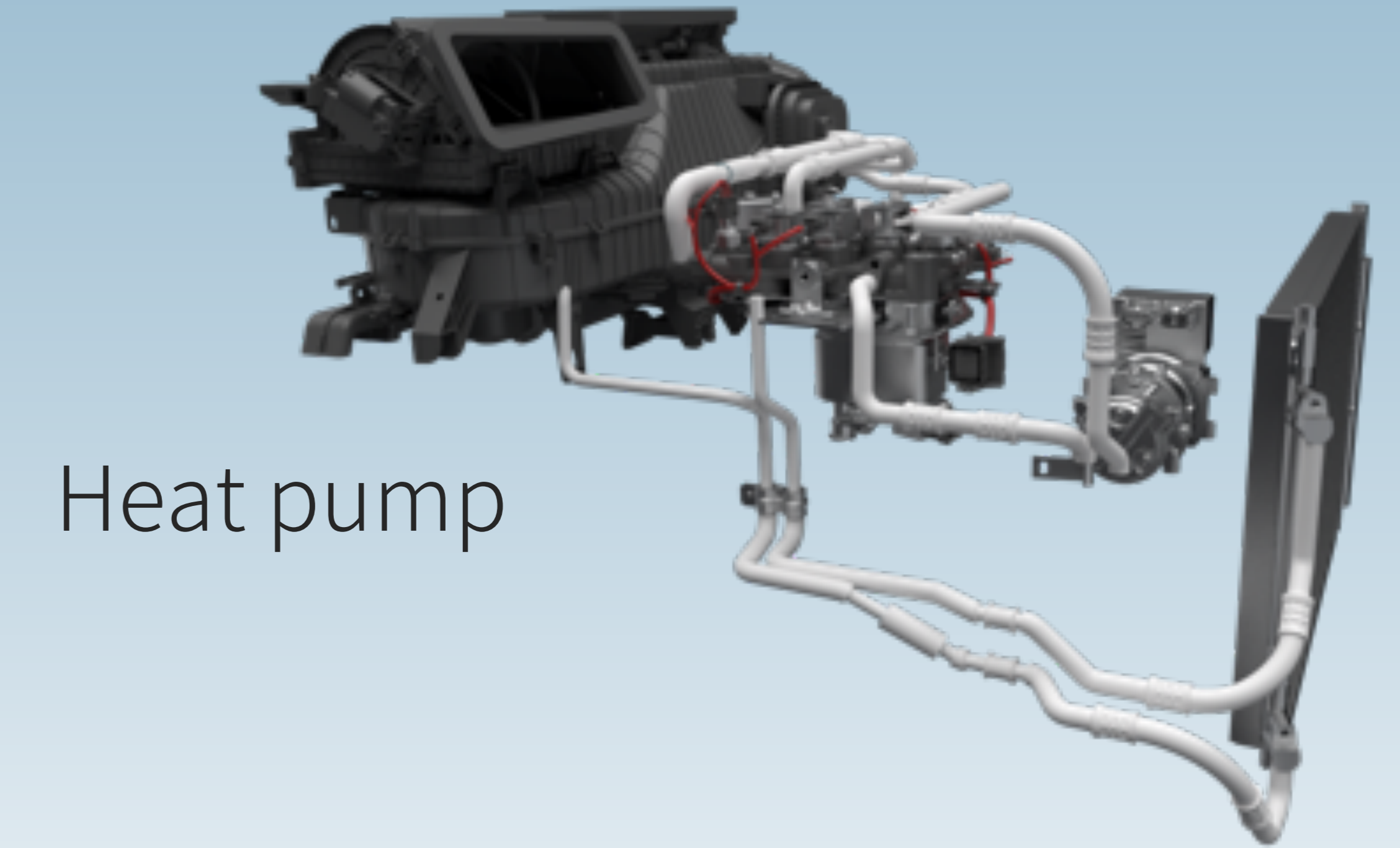
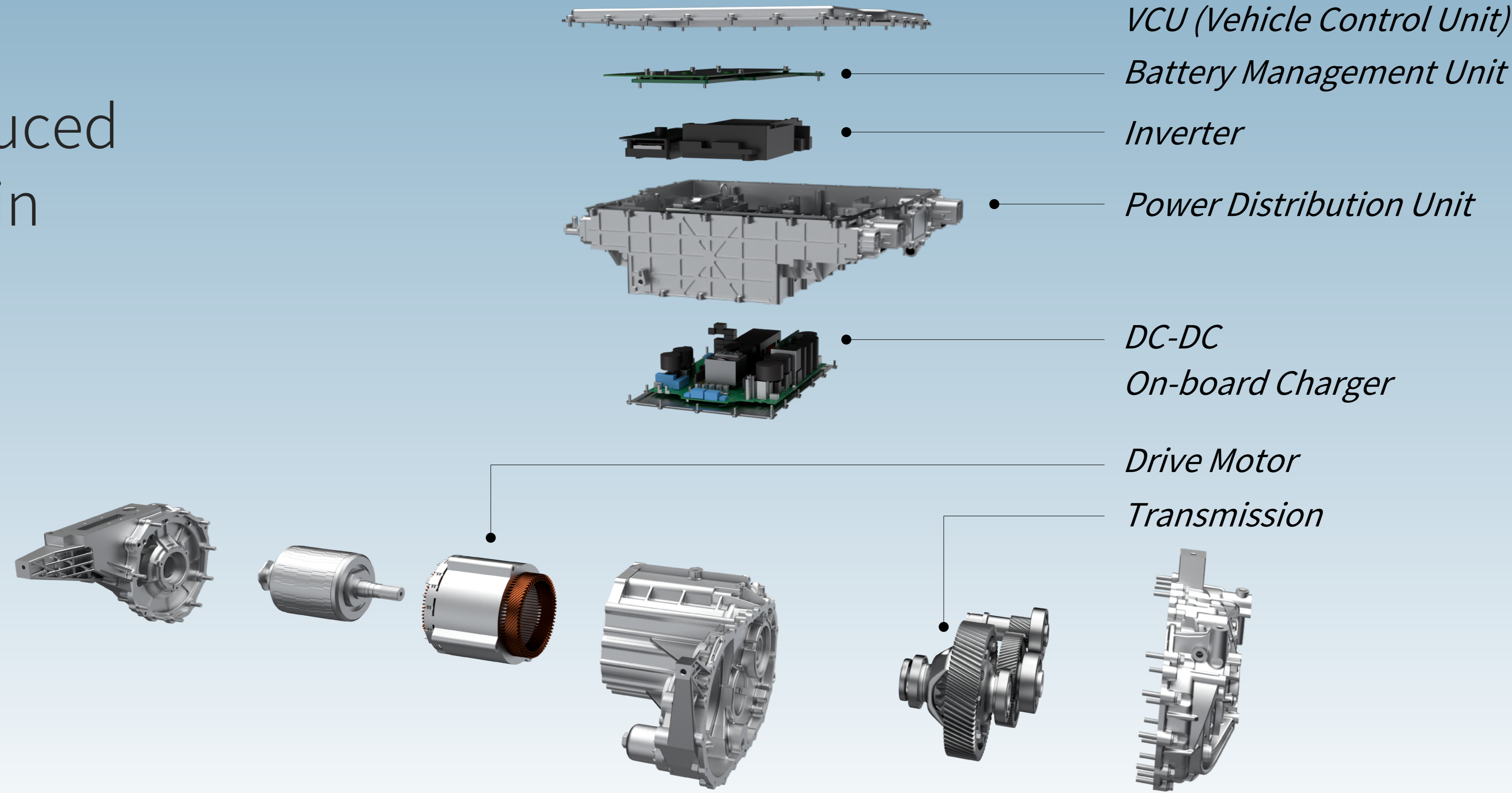

Intelligence

High efficiency domain control architecture
Industry's first drivetrain domain controller

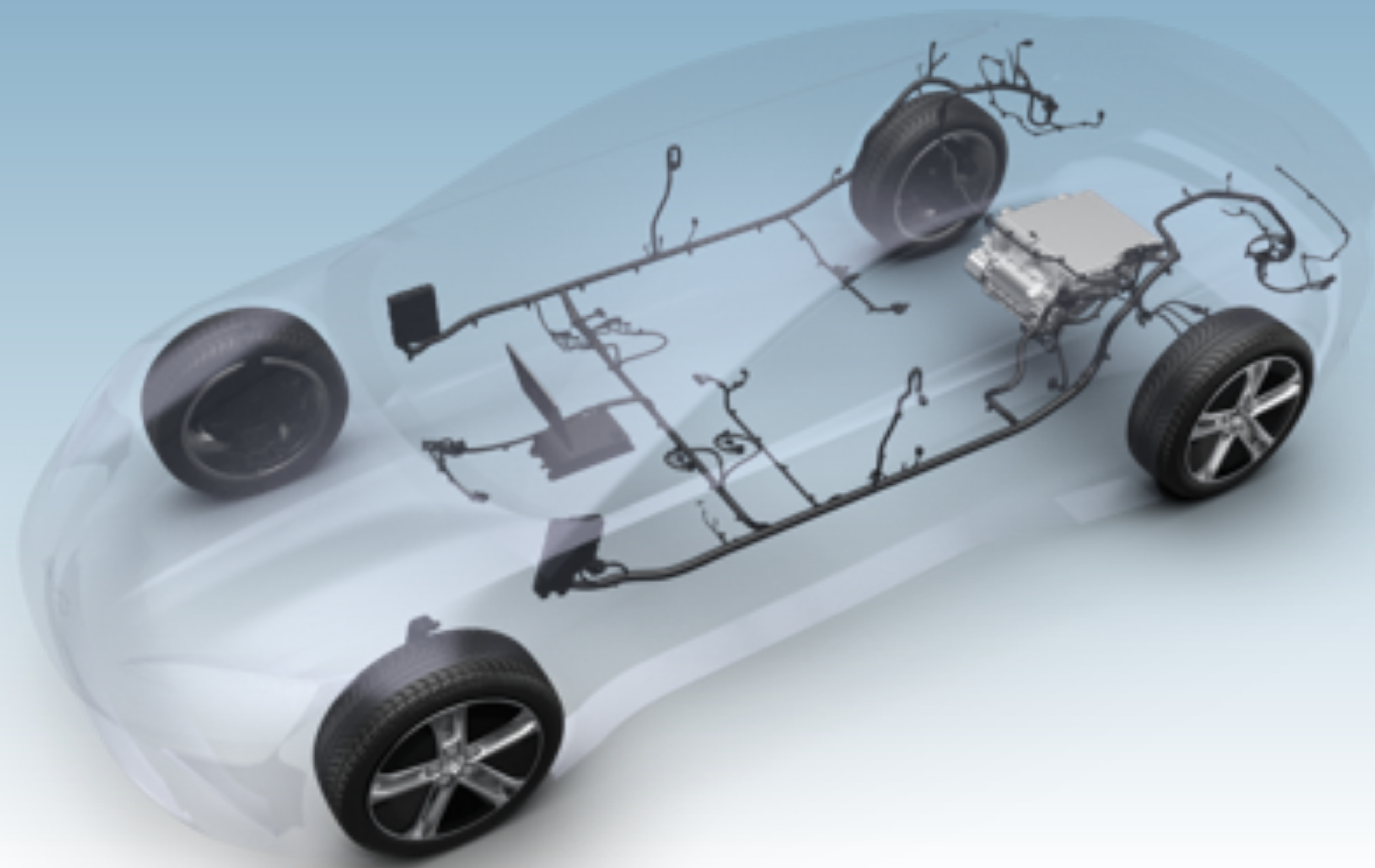

Spacious cabin

Traditional platform



e-Platform 3.0



Spacious cabin

Longer wheelbase

Flat rear floor



Traditional platform
e-Platform 3.0



2022 Product Portfolio

BYD

TANG E-segment SUV



HAN E-segment Sedan



ATTO 3 C-segment SUV

